

SNOW BRACKET A

DESCRIPTION

- Designed for use with concrete tiles which are installed using horizontal battens.
- No fasteners required.
- Powder coated to match roofing material color
- Overall dimensions: 18-1/2" L X 1-3/16" W X 4-5/8" H

MATERIALS

- Steel :: 16 ga
- Copper :: 48 oz. (ASTM B152)
- Cor-Ten[®] :: 16 ga (ASTM A606)
- Stainless Steel :: 16 ga
- Aluminum :: .063" (H32 - ASTM B209)

COLORS/FINISHES

- Electro-galvanized steel (ASTM A879)
- Hot-dipped galvanized steel
- Mill finish Copper
- Mill finish Aluminum
- Powder coating available in RAL Standard colors
- Visit <http://tra-mage.com/color-chart/> to see color chart

NOTE: Due to specific job conditions, TRA-MAGE will only warranty a snow retention system/layout that has been designed by TRA-MAGE.



FOR NEW CONSTRUCTION

**USED ON: COLUMBIA, EAGLE, HANSON,
MONIER, LIFETILE, UNICRETE WESTILE
& OTHER SIMILAR TILES**

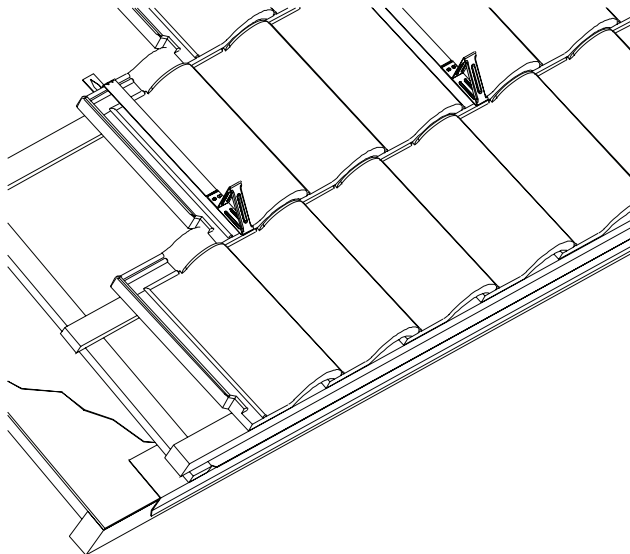

Bracket is installed with triangular end of bracket at butt end of roof tile and upper end under the course above.

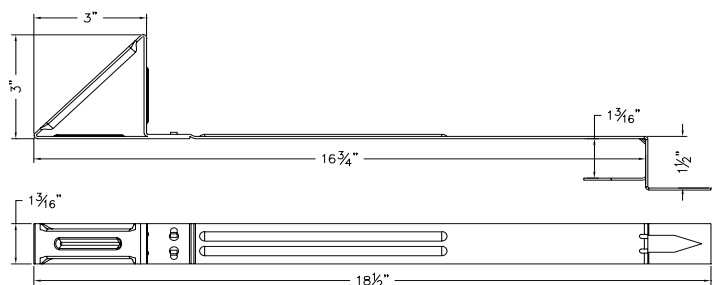

BRACKET INSTALLATION

DO NOT SCALE

BRACKET DIMENSIONS

DO NOT SCALE